

owner's manual



ASTRAL-TC *series*

shademaker
architectural shade

WARRANTY:

Upon receipt of your Astral-TC, please check to ensure you have received all of the parts.

NOTE: Wind damage is not covered under any manufacturer's warranty.

5 Year Limited Warranty includes the LIBRA, ASTRAL-TC, SIRIUS, POLARIS, ORION and GALAXY styles. This includes the mast, boom, head fitting, elbow, center pole/sidepost, arms, ribs, top and bottom hub, and stainless steel hardware only. If there is damage under the warranty, Shademaker will replace and/or repair any item listed in this category at its discretion. Labor charges are not covered under this limited warranty.

10 Year Limited Warranty includes the Sunbrella® awning & marine grade Fabric Collection. Visit www.sunbrella.com/warranty for more details. Labor charges are not covered under this limited warranty.

5 Year Limited Warranty applies to Sunbrella Firesist®, Sunbrella Firesist® PLUS and Sunbrella® furniture grade, and O'bravia® awning grade fabrics. Labor charges are not covered under this limited warranty.

1 Year Limited Warranty covers base wheels and the powder coat finish on all bases. If the powder coat finish flakes, bubbles, peels or loses color; Shademaker will re-finish or replace the defective bases at its discretion. Normal wear and tear is not covered under this limited warranty. Labor charges are not covered under this limited warranty.

Caution: Seaside and indoor pool use, salt & chlorides can accumulate on the powder coat finish, leading to finish failure. Failure or neglect to make needed cleanings may cause paint to blister, and such failure will void limited warranty.

Exclusions: Wind damage, acts of nature (such as, but not limited to, freezing or any type of extreme weather). Failures caused by abusive use and normal wear and tear are not covered under this warranty. Any Galaxy style that does not have spacer buttons installed.

Parts can be ordered under warranty at no charge, if found that the damage is a manufacture defect and/or purchased out of warranty to make them whole again.

IMPORTANT RESTRICTION FOR SM PRODUCTS WARRANTY SERVICE:

Shademaker restricts warranty service for SM products to the country where Shademaker or its authorized SM retail Dealers originally sold the product.

Those filing warranty claims will be responsible for all shipping, handling and freight charges on all claims to Shademaker in Baldwin Park, CA. All warranty claims must be submitted with the original proof of purchase, date of purchase, name of dealer and the description of the damage. An authorized Shademaker RA# must be listed on all products being returned. The Shademaker warranty is not transferable. Shademaker reserves the right to repair, replace and/or redesign any product that is returned under a warranty claim.

For current warranty information, please visit www.shademakerusa.com.

IMPORTANT:

Please read this entire manual before installing or operating your Astral-TC umbrella.

ASTRAL-TC WIND RESISTANCE GUIDELINES:

Moderate to Strong Winds (when mounted)

When installed properly, the Astral-TC is engineered to handle strong wind conditions in the open canopy position. Please adhere to these common sense wind guidelines:

1. As winds get stronger, or as gusts increase, the canopy should be lowered to the folded and strapped position.
2. If unattended for an extended period of time, the Astral-TC should be left in the folded and strapped position.
3. In anticipation of, and during extremely severe weather conditions, it is advisable to remove and store the entire Astral-TC structure to protect it from storm-related debris.

SPECIFICATIONS

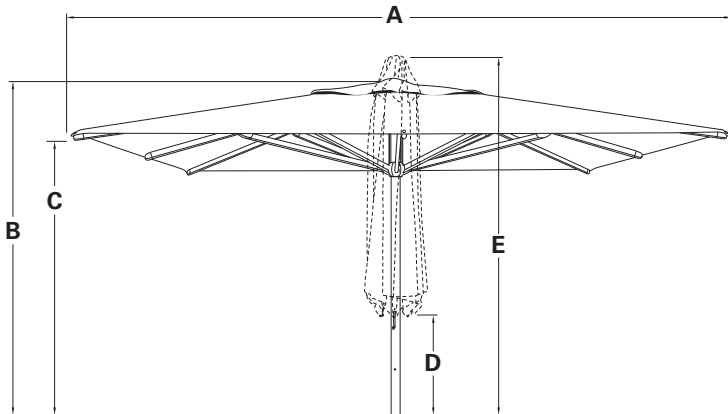

Item No.	A Canopy Width	B Overall Height (Opened)	C Arm End Height (Opened)	D Arm End Height (Closed)	E Overall Height (Closed)
ASTRAL-TC-35S	11'5"	9'2"	7'5"	3'4"	11'5"
ASTRAL-TC-40S	13'1"	9'4"	7'4"	2'11"	12'
ASTRAL-TC-50S	16'4"	9'6"	7'5"	1'8"	13'2"
ASTRAL-TC-50	15'2"	9'2"	7'5"	3'4"	12'3"

Weight: Approximately 128-150 lbs.
 Mast Shape & Diameter: 3.25" Round
 Wall Thickness of Mast: .104" - .15"
 Rib Thickness: .118"

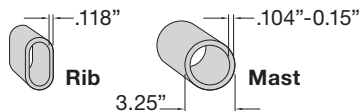
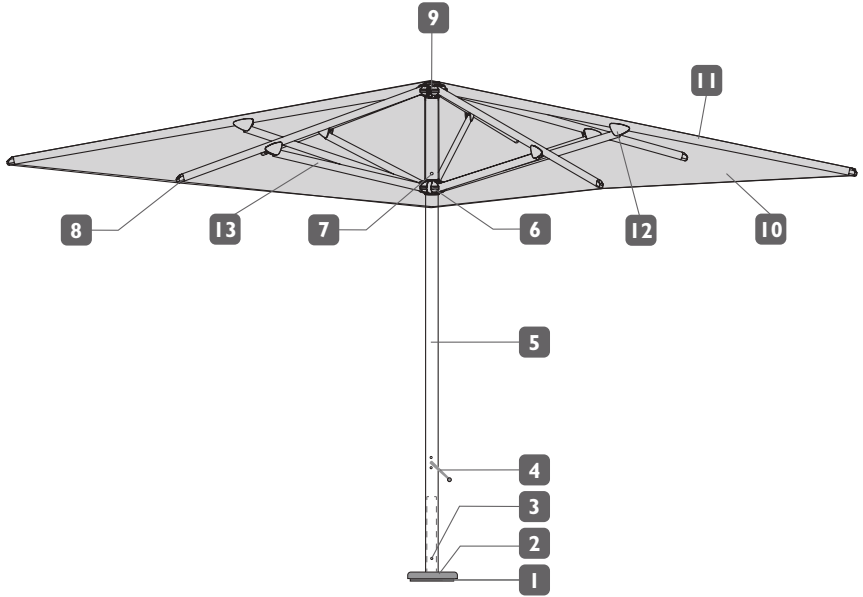

DIAGRAM & PARTS LIST



- | | |
|-----------------------------------|--------------------|
| 1. Internal Stem | 8. Arm End Fitting |
| 2. Internal Stem Cover (optional) | 9. Hub (Upper) |
| 3. Locking Screws | 10. Canopy |
| 4. Crank Handle | 11. Long Arm |
| 5. Pole | 12. Strop (Hinge) |
| 6. Hub (Lower) | 13. Strut |
| 7. Anti-rotation pin | |

INSTALLATION OPTIONS AND GUIDELINES

There are four standard installation options which provide the best stability for the Astral-TC. Depending on your situation, you will have requested one or more of the Astral-TC base options at the time of your order. Note: Permanent mount recommended for Astral-TC-50 styles.

- 1. CONCRETE MOUNT KIT** - This kit includes a base plate, four (4) plate bolts, and one (1) allen wrench. Recommend installation by a licensed contractor.
- 2. IN-GROUND MOUNT KIT** - This kit includes in-ground fitting, four (4) plate bolts, and one (1) allen wrench. Recommend installation by a licensed contractor.
- 3. STEEL BASE WEIGHT** - 213 lbs. Square steel base weight is available (SM PLATE required). We recommend a minimum of 400-700 lbs. of steel base weights for this umbrella (depending on the size of your umbrella).
- 4. STEEL BASE FRAME** - You may opt to use a free standing base for your umbrella. We recommend a minimum of a 400-700 lbs. base weight for this umbrella (depending on the size of your umbrella). **NOTE:** If using a free-standing steel frame, wind guidelines change from light to moderate winds to light winds only.

NOTE: REFER TO BASE WEIGHT MATRIX AND SEPARATE MANUAL FOR BASE ASSEMBLY PRIOR TO PROCEEDING.

ASSEMBLY INSTRUCTIONS

Two-person team is recommended for assembly.

By now, you have installed your mount kit, SM PLATE onto your steel base weight, or have set up your steel base frame with recommended base weight.

Option A: If you wish to use optional internal stem cover, proceed below. Otherwise, if you wish to not use cover and for a quicker installation, skip to Option B on page 6.

Remove internal stem from pole. Install internal stem onto mount kit, SM PLATE or steel base frame with supplied 5 bolts and washers using allen wrench. *Do not completely tighten.* **Note:** Do not use power drill. May cause damage to umbrella.



Slide internal stem cover over Astral-TC bottom pole. Using a two person team, lift umbrella with cover and insert bottom pole into internal stem. Tighten 5 bolts with provided allen wrench to secure umbrella in place. **Note:** Do not use power drill. May cause damage to umbrella. Slide internal stem cover down to cover internal stem. Once complete, proceed to page 7.

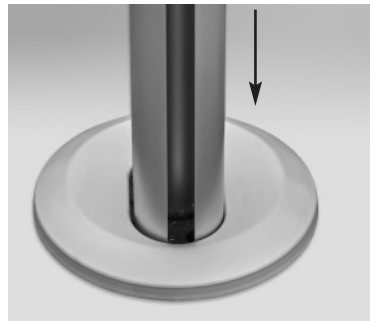

(Internal Stem Cover shown on Orion style)

Option B: If you wish not to use optional internal stem cover, proceed below.

Using a two person team, lift umbrella with attached internal stem and install umbrella onto mount kit, SM PLATE on your steel base weight. Tighten 5 bolts with provided allen wrench to secure umbrella in place. **Note:** Do not use power drill. May cause damage to umbrella. Once complete, proceed to page 7.



Attaching Astral-TC to Internal Stem

Rotate Astral-TC pole until the bore holes for the locking screws in the internal stem line up in the pole. Tighten locking screws into the internal stem to secure.

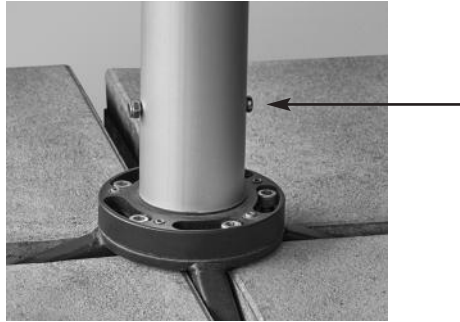

Leveling Umbrella

Check the vertical position of the umbrella with a level tool.



If the umbrella is not level, lift optional internal stem cover to access internal stem. Untighten the 5 bolts with 1-2 rotations (do not completely untighten bolts!). The internal stem can rotate without applying force. Correct the vertical level position with leveling screws.



Once leveled, re-tighten the 5 bolts with allen wrench on internal stem. **Note:** Do not use power drill. May cause damage to umbrella. Slide optional internal stem cover down and cover internal stem.

You are now ready to operate your umbrella!

OPERATING INSTRUCTIONS

Remove all packaging from umbrella.

To Open Canopy

1. To open the canopy, first undo the strap and position yourself under the canopy arms so you can easily reach the crank handle. **CAUTION: NEVER FORCE THE ARMS.** If you experience any resistance, make sure all arms are freed manually to facilitate opening.



2. Once the arms have been freed manually, insert crank handle into gear.
3. Turn crank handle clockwise until the canopy is taut. The slider automatically locks with the anti-rotation pin.

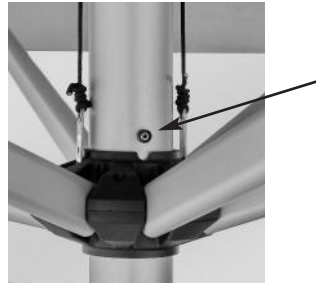

To Close Canopy

1. Insert crank handle into gear. Turn crank handle counter-clockwise until umbrella is completely closed.
2. Strap canopy to the mast. When fastening strap make sure that no fabric is caught in between the arms of the Astral-TC as this can result in rubbing and damage to the canopy. Use a protective cover to protect your fabric and prolong the life of the canopy (included).



Open position



Closed position



TO PROPERLY FOLD CANOPY

The 100% solution dyed canopy will last longer if you fold it as it was packed and shipped. This technique is similar to the way a parachute is folded and is especially important when folding the canopy for seasonal storage or when left in the closed position for an extended period of time.

Using this technique at all times will significantly extend the life of the canopy.

1. When the canopy has been fully lowered, stand in front of the canopy structure and begin the folding process by pulling out two panels opposite the mast.
Pull the two panels together and roll tight into the canopy.
2. Once rolled tight, pull adjacent panels out one at a time and fold to the center, alternating sides until all the panels have been pulled out from the arms and folded into the center.
3. Wrap and secure strap around the canopy.



PROTECTIVE COVER

1. Screw rods together and insert into slit of the cover.
2. Unzip cover.
3. Using the rod as a guide, slide cover over your umbrella.
4. Pull on string to zip down your cover and tie.

MAINTAINING FRAME & FITTINGS

1. Hose frame with water periodically, more often if installation is in a salty or industrial environment.
2. Inspect the installation fitting, mount bolts, rib spacers, etc. on a regular basis and tighten if necessary.

MAINTAINING CANOPY FABRIC

1. Clean up spills and stains right away. Spills can be removed by using a clean absorbent cloth.
2. For general maintenance, use a soft brush to remove dust and dry soil. Wash down with clean, warm water (i.e., garden hose) every so often to avoid dirt becoming ingrained. Allow the fabric to air dry before closing the canopy.
3. If a thorough cleaning is necessary, sponge over the fabric using a mild soap solution (2% solution). Rinse well with plenty of water to remove all soap residue.
4. Never use detergents, cleaning fluids or solvents. Grease and oil stains may be removed by using turpentine or similar with an absorbent cloth.
5. Please visit the fabric websites for more details: www.shademakerusa.com or www.sunbrella.com
6. Use protective canopy cover during storage or when not in use.

REMOVAL & REPLACEMENT OF CANOPY

Follow these instructions should you choose to replace your canopy with a new canopy.

1. Lower the canopy to the closed position.
2. Remove the button/screw at the end of each arm.
3. Remove canopy from structure.
4. To replace the canopy, reverse the above process.

shademaker

architectural shade

13401 Brooks Drive
Baldwin Park, CA 91706
p 626.338.8810
f 626.338.8816
info@shademakerusa.com

shademakerusa.com