

shademaker

architectural shade

13401 Brooks Drive
Baldwin Park, CA 91706
p 626 338 8810 f 626 338 8816

shademakerusa.com

SHOWROOM
Chicago - 1655 Merchandise Mart



shademaker
architectural shade

2022 COLLECTIONS



shademaker
architectural shade



SHOWN | **POLARIS-30S**
In 4678 Marine Blue



INTRODUCTION	02
LIBRA	05
ASTRAL-TC	11
SIRIUS	17
POLARIS	23
ORION	29
GALAXY	35
MOUNT & BASE OPTIONS	41
BASE WEIGHT MATRIX	45
REPLACEMENT PARTS & OPTIONS	46
FABRICS & FRAME FINISHES	48
PRODUCT SPECIFICATIONS	52
TERMS & CONDITIONS	56
MAINTENANCE & WARRANTY	59

shademaker

architectural shade

The architectural essence of Shademaker umbrellas begin with a unified design, form, and structure. From this foundation, our contemporary styling, incorporating clean anodized frames and designer performance fabrics, defines a signature look found within each umbrella in the Shademaker collection.

With exacting attention to detail, Shademaker delivers the highest standards of quality, strength, and durability. From profile thickness to innovative functionality, each and every umbrella that bears the Shademaker name is recognized as the finest shade solution available.



SHOWN | POLARIS-30S
In 4677 Tuscan





collection

LIBRA



05

SHOWN | **LIBRA-20S** in 4624 Sky Blue, **LIBRA-25** in 4602 Sunflower Yellow



SHOWN | **LIBRA-25S**
In 58033 Shore Classic



LIBRA

The Libra's simplistic design features an easy to use push up system with secure automatic locking. The Libra's internal counterweight design ensures the umbrella opens easily and glides to a close with ease.

// FEATURES

- Easy push-up and automatic locking system
- Internal counterweight to close with ease
- Durable high performance hub and fittings
- External mast stem for mount kit and steel base weight options
- Includes protective cover

Mount Kits	42
Steel Base Weights & Base	43
Steel & Cast Aluminum Bases	44
Fabrics & Frame Finishes	48
Product Specifications	52



Item No.	Size Meters Feet	Canopy Shape	Recommended Minimum Base Weight	MSRP Price Group 1 Sunbrella® Awning Grade	MSRP Price Group 2 O'bravia® Awning Grade Sunbrella® / Outdura® / Bliss Furniture Grade
LIBRA-20S	2.0m 6' 6"	Square	100 lbs.	-----	-----
LIBRA-25*	2.5m 8' 2"	Octagon	100 lbs.	-----	-----
LIBRA-25S*	2.5m 8' 2"	Square	100 lbs.	-----	-----

* Quick-ship item. See page 55.





collection

ASTRAL-TC

11



SHOWN | **ASTRAL-TC-40S**
In 5816 Aqua



ASTRAL-TC

This imposing centerpost umbrella is the ideal solution for most commercial applications. The telescoping Astral-TC is designed to open and close easily over tables and chairs with a few simple rotations of the removable crank handle.

// FEATURES

- Telescopic mast
- Effortless crank lift system
- Removable crank handle
- Durable high performance hub and fittings
- Galvanized internal mast stem
- Includes internal mast stem cover
- Includes protective cover

Mount Kits	42
Steel Base Weights & Base	43
Fabrics & Frame Finishes	48
Product Specifications	52



Item No.	Size Meters Feet	Canopy Shape	Recommended Minimum Base Weight	MSRP Price Group 1 Sunbrella® Awning Grade	MSRP Price Group 2 O'bravia® Awning Grade Sunbrella® / Outdura® / Bliss Furniture Grade
ASTRAL-TC-35S	3.5m 11' 5"	Square	400 lbs.	-----	-----
ASTRAL-TC-40S	4.0m 13' 1"	Square	500 lbs.	-----	-----
ASTRAL-TC-50	5.0m 16' 4"	Octagon	600 lbs.*	-----	-----
ASTRAL-TC-50S	5.0m 16' 4"	Square	700 lbs.*	-----	-----

* Permanent mount recommended.



collection

SIRIUS

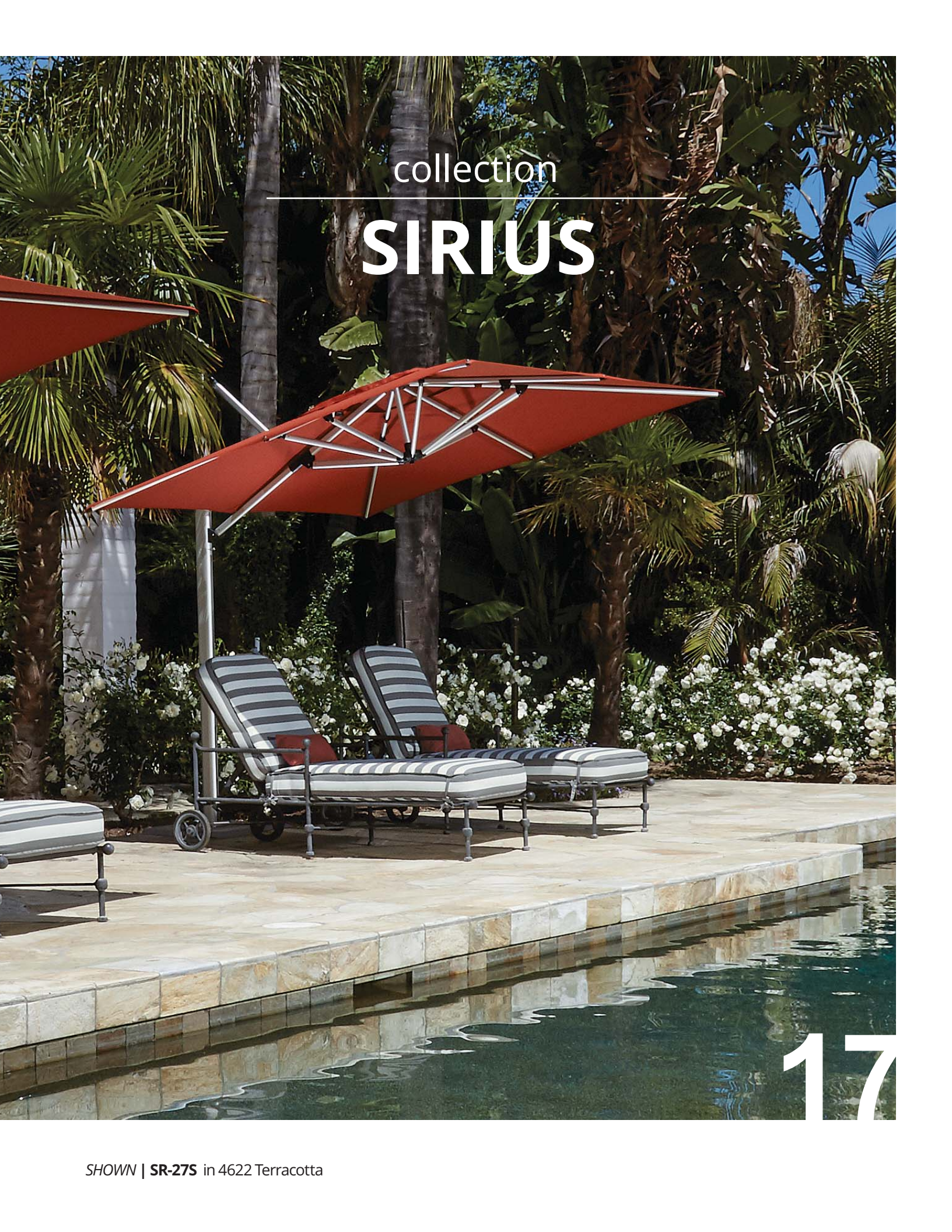

17

SHOWN | SR-27S-AW
In 5816 Aqua





SIRIUS

This sleek styling sidepost umbrella with 360° rotation and easy to use front to back tilt function provides just the right amount of shade throughout the day.

// FEATURES

- 3 front to back tilt positions
- 8 locking positions with 360° rotation
- Simple to operate crank lift system
- Removable crank handle
- Built-in light adapter
- Durable high performance hub and fittings
- Stainless steel hardware for longevity
- Galvanized internal mast stem
- Includes internal mast stem cover
- Includes protective cover

Mount Kits	42
Steel Base Weights & Base	43
Fabrics & Frame Finishes	48
Product Specifications	53



Item No.	Size Meters Feet	Canopy Shape	Recommended Minimum Base Weight	MSRP Price Group 1 Sunbrella® Awning Grade	MSRP Price Group 2 O'bravia® Awning Grade Sunbrella® / Outdura® / Bliss Furniture Grade
SR-27S	2.7m 8' 9"	Square	350 lbs.	-----	-----
SR-30	3.0m 9' 9"	Octagon	350 lbs.	-----	-----
SR-30S	3.0m 9' 9"	Square	350 lbs.	-----	-----
SR-35	3.5m 11' 5"	Octagon	450 lbs.	-----	-----





collection

POLARIS

23



SHOWN | POLARIS-30S
In 48103S Cast Ocean



POLARIS

The Polaris impresses in both form and function. This designer sidepost umbrella offers an effortless crank and infinite tilt function to provide shade coverage at any time of the day. Sophisticated styling and superb construction make the Polaris one of our most popular models.

// FEATURES

- Simple to operate infinite front to back tilt system
- 8 locking positions with 360° rotation
- Built-in light adapter
- Durable high performance hub and fittings
- Stainless steel hardware for longevity
- Galvanized internal mast stem
- Includes internal mast stem cover
- Includes protective cover

Mount Kits	42
Steel Base Weights & Base	43
Fabrics & Frame Finishes	48
Product Specifications	53



Item No.	Size Meters Feet	Canopy Shape	Recommended Minimum Base Weight	MSRP Price Group 1 Sunbrella® Awning Grade	MSRP Price Group 2 O'bravia® Awning Grade Sunbrella® / Outdura® / Bliss Furniture Grade
POLARIS-30S	3.0m 9' 9"	Square	450 lbs.	*****	*****
POLARIS-35S	3.5m 11' 5"	Square	550 lbs.	*****	*****
POLARIS-340RT	3.0m x 4.0m 10' x 13'	Rectangle	550 lbs.	*****	*****
POLARIS-40	4.0m 13' 1"	Octagon	700 lbs.*	*****	*****
POLARIS-40S	4.0m 13' 1"	Square	700 lbs.*	*****	*****

* Permanent mount recommended.



collection

ORION

29

SHOWN | **OR-27S** in 54048 Charcoal

SHOWN | **OR-40** and **LIBRA-20S**
In 4608 Black





ORION

Designed with simplicity in mind and constructed with superior high wind resistance, this popular sidepost umbrella is the ideal solution for any outdoor space.

The detachable canopy structure allows for easy storage and maintenance.

// FEATURES

- Canopy structure easily detaches for storage
- 8 locking positions with 360° rotation
- Simple to operate crank lift system
- Removable crank handle
- Built-in light adapter
- High-grade stainless steel cable
- Durable high performance hub and fittings
- Galvanized internal mast stem
- Includes internal mast stem cover
- Includes protective cover

Mount Kits	42
Steel Base Weights & Base	43
Fabrics & Frame Finishes	48
Product Specifications	54



Item No.	Size Meters Feet	Canopy Shape	Minimum Base Weight	MSRP Price Group 1 Sunbrella® Awning Grade	MSRP Price Group 2 O'bravia® Awning Grade Sunbrella® / Outdura® / Bliss Furniture Grade
OR-27S	2.7m 8' 9"	Square	350 lbs.	-----	-----
OR-30	3.0m 9' 9"	Octagon	350 lbs.	-----	-----
OR-30S	3.0m 9' 9"	Square	350 lbs.	-----	-----
OR-40	4.0m 13' 1"	Octagon	500 lbs.	-----	-----



collection

GALAXY



35

SHOWN | GALAXY-35S in 4608 Black



SHOWN | GALAXY-35S
In 4603 Jockey Red



GALAXY

Our Galaxy is the GIANT of all sidepost styles;
an umbrella superior in design, durability and size.

// FEATURES

- Superior in design and durability
- Durable high performance hub and fittings
- Includes protective cover

Mount Kits	42
Fabrics & Frame Finishes	48
Product Specifications	54



Item No.	Size Meters Feet	Canopy Shape	Minimum Base Weight	MSRP Price Group 1 Sunbrella® Awning Grade	MSRP Price Group 2 O'bravia® Awning Grade Sunbrella® / Outdura® / Bliss Furniture Grade
GALAXY-35S	3.5m 11' 5"	Square	Mount	-----	-----
GALAXY-40S	4.0m 13' 1"	Square	Mount	-----	-----
GALAXY-50	5.0m 16' 4"	Octagon	Mount	-----	-----



options | **MOUNT KITS, BASES, FABRICS & FRAME FINISHES**



options

**MOUNT KITS, BASES,
FABRICS & FRAME FINISHES**

41

MOUNT OPTIONS

All Shademaker styles are designed to be mounted. Our Mount Kits (concrete and in-ground applications) are the recommended and preferred method to properly secure your umbrella.

mount kits for libra styles

Item No.	Description	Plate Dia.	Thickness	Weight	Cube	MSRP
MKC21	concrete mount kit	8.46"	.47"	6.84 lbs.	.05	-----
	Case Pack	Case Weight	Case Cube			
	10	83 lbs.	.46			
Item No.	Description	Plate Dia.	Thickness	Weight	Cube	MSRP
MKG21	in-ground mount kit	8.39"	.39"	11.69 lbs.	1.08	-----
	Case Pack	Case Weight	Case Cube			
	4	59 lbs.	4.33			Stem Dia: 2.38" Depth: 19.6"

mount kits for astral-tc, sirius, polaris and orion styles

Item No.	Description	Plate Dia.	Thickness	Weight	Cube	MSRP
MKC17	concrete mount kit	8.5"	.63"	9.04 lbs.	.08	-----
	Case Pack	Case Weight	Case Cube			
	5	51 lbs.	.39			
Item No.	Description	Plate Dia.	Thickness	Weight	Cube	MSRP
MKG17	in-ground mount kit	6.3"	.38"	10.04 lbs.	.70	-----
	Case Pack	Case Weight	Case Cube			
	2	23 lbs.	1.4			Stem Dia: 2.38" Depth: 19.53"

mount kits for galaxy styles

Item No.	Description	Plate Dia.	Thickness	Weight	Cube	MSRP
GMKC21	concrete mount kit	15.125"	.64"	22.05 lbs.	.38	-----
Item No.	Description	Plate Dia.	Thickness	Weight	Cube	MSRP
GMKG21	in-ground mount kit	15.75"	.63"	48.51 lbs.	4.33	-----
						Stem Dia: 2.7" Depth: 18.75"

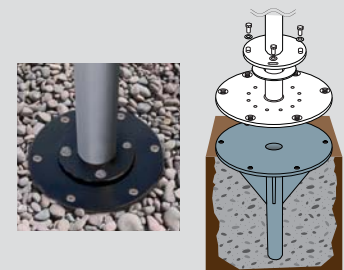
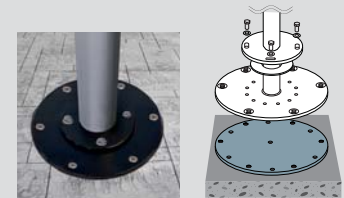
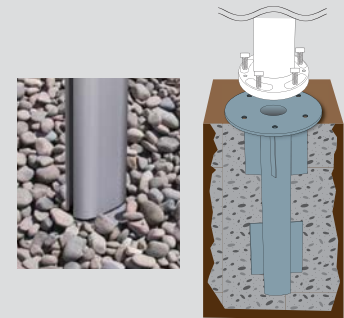
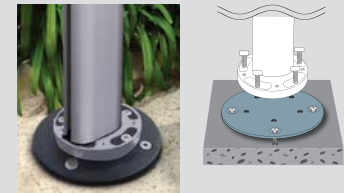
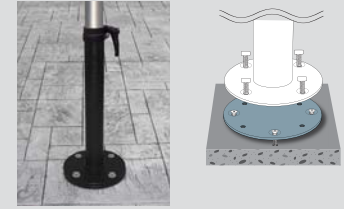

STEEL BASE WEIGHTS & BASE

Shademaker steel base weights may be purchased individually or in multiple sizes and stacked to meet base weight requirements.



square

Black finish



round

Black finish



Silver finish



titan base | galvanized steel frame + aluminum lid for astral-tc, sirius, polaris and orion styles

Item No.	Size	Weight	Cube	Total Weight with Pavers	MSRP
BGT850-SG	40.5"x6.4"	118.1 lbs.	10.79	850 lbs.	-----

Shadow Graphite finish

NOTE: SM PLATE (Adapter Plate) REQUIRED.

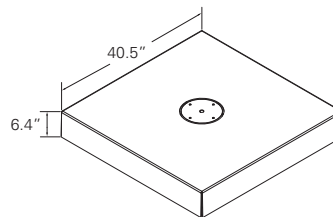

Accommodates (32) 12"x12"x1.5" pavers (not included)

steel base weights for libra styles

Item No.	Weight	Size	Thickness	MSRP
SB50SQ*	50 lbs.	17"	.675"	-----
SB100SQ	100 lbs.	24"	.675"	-----
SB125SQ	125 lbs.	27"	.675"	-----

Item No.	Weight	Size	Thickness	MSRP
SB50R*	50 lbs.	19"	.675"	-----
SB100R	100 lbs.	27"	.675"	-----
SB125R	125 lbs.	30"	.675"	-----

*NOTE: When stacking steel base weights, the SB50SQ and SB50R CAN ONLY BE USED AS THE TOP WEIGHT.

geomet steel base weight for astral-tc, sirius, polaris and orion styles

Item No.	Weight	Size	Thickness	MSRP
SBGC100SQ	100 lbs.	26"	.6"	-----
SBGC200SQ	200 lbs.	36"	.6"	-----

NOTE: SM PLATE (Adapter Plate) REQUIRED.

adapter plate for geomet steel base weight and titan base

Black finish

Item No.	Weight	Size	Thickness	MSRP
SM PLATE	8 lbs.	8.5"	.6"	-----



ADDITIONAL BASES FOR LIBRA

steel base w/casters

Item No.	Finish	Weight	Cube	MSRP
BSK1200	bronze	120 lbs.	1.4	-----
BSK1209	black	120 lbs.	1.4	-----

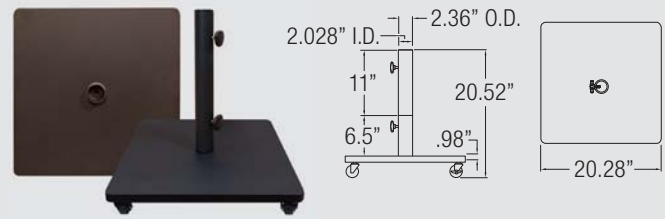

cast aluminum bases

monaco (square) w/wheels & handle

Item No.	Finish	Weight	Cube	MSRP
BKMSQ1000	bronze	100 lbs.	1.75	-----
BKMSQ1003	white	100 lbs.	1.75	-----
BKMSQ1005T	platinum	100 lbs.	1.75	-----
BKMSQ1009	black	100 lbs.	1.75	-----

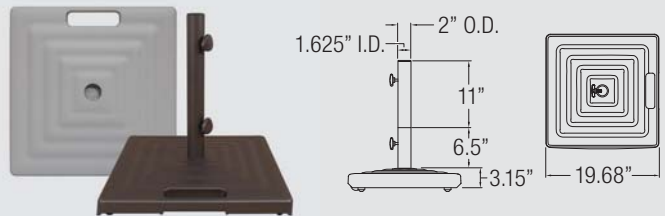

monaco (round) w/wheels & handle

Item No.	Finish	Weight	Cube	MSRP
BKM1000	bronze	100 lbs.	2	-----
BKM1003	white	100 lbs.	2	-----
BKM1005T	platinum	100 lbs.	2	-----
BKM1009	black	100 lbs.	2	-----

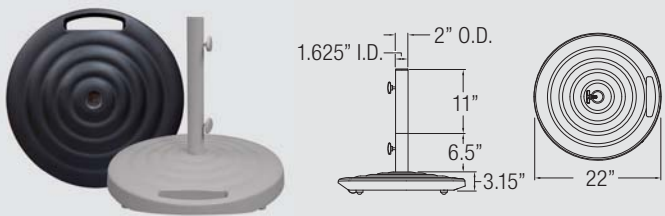

commercial

Item No.	Finish	Weight	Cube	MSRP
BA1500	bronze	150 lbs.	2.8	-----
BA1509	black	150 lbs.	2.8	-----

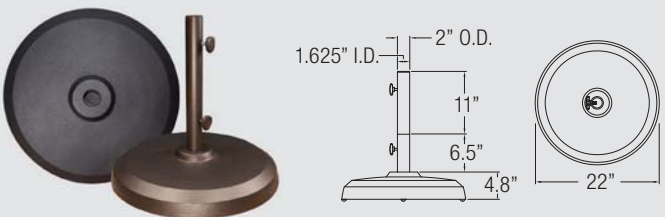

athens w/wheels NEW

Item No.	Finish	Weight	Cube	MSRP
BTT100-AW	arctic white	108 lbs.	3.51	-----
BTT100-SG	shadow graphite	108 lbs.	3.51	-----

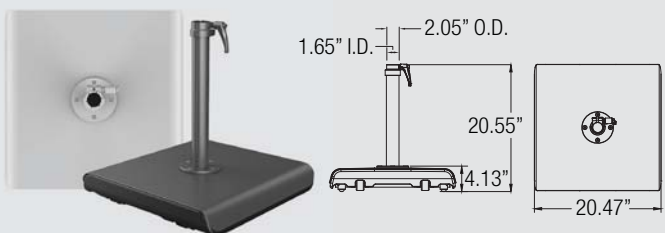

add-on weight

Optional cast iron weight adds 30 lbs. to our athens and monaco bases.

Item No.	Weight	MSRP
BW30	30 lbs	-----

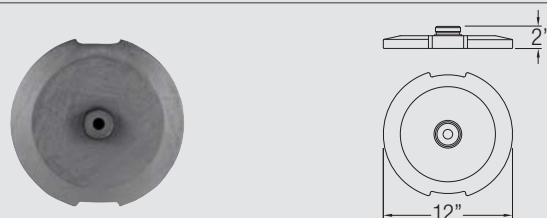

BASE WEIGHT MATRIX

Item No.	Size	Canopy Shape	Minimum Base Weight	Mount and Base Options		
				Recommended	Alternate 1	Alternate 2
LIBRA-20S	6' 6"	SQ	100 lbs.	athens, monaco	(SB) steel base weight	BSK120x, BA150x
LIBRA-25	8' 2"	OCT	100 lbs.	athens, monaco	(SB) steel base weight	BSK120x, BA150x
LIBRA-25S	8' 2"	SQ	100 lbs.	athens, monaco	(SB) steel base weight	BSK120x, BA150x
ASTRAL-TC-35S	11' 5"	SQ	400 lbs.	(2) SBGC200SQ	mount kit	titan base
ASTRAL-TC-40S	13' 1"	SQ	500 lbs.	mount kit	(2) SBGC200SQ + (1) SBGC100SQ	titan base
ASTRAL-TC-50*	16' 4"	OCT	600 lbs.	mount kit	(3) SBGC200SQ	titan base
ASTRAL-TC-50S*	16' 4"	SQ	700 lbs.	mount kit	(3) SBGC200SQ + (1) SBGC100SQ	titan base
SR-27S	8' 9"	SQ	350 lbs.	(2) SBGC200SQ	titan base	mount kit
SR-30	9' 9"	OCT	350 lbs.	(2) SBGC200SQ	titan base	mount kit
SR-30S	9' 9"	SQ	350 lbs.	(2) SBGC200SQ	titan base	mount kit
SR-35	11' 5"	OCT	450 lbs.	(2) SBGC200SQ + (1) SBGC100SQ	titan base	mount kit
POLARIS-30S	9' 9"	SQ	450 lbs.	(2) SBGC200SQ + (1) SBGC100SQ	titan base	mount kit
POLARIS-35S	11' 5"	SQ	550 lbs.	(3) SBGC200SQ	titan base	mount kit
POLARIS-340RT	10' x 13'	RT	550 lbs.	mount kit	(3) SBGC200SQ	titan base
POLARIS-40*	13' 1"	OCT	700 lbs.	mount kit	(3) SBGC200SQ + (1) SBGC100SQ	titan base
POLARIS-40S*	13' 1"	SQ	700 lbs.	mount kit	(3) SBGC200SQ + (1) SBGC100SQ	titan base
OR-27S	8' 9"	SQ	350 lbs.	titan base	(2) SBGC200SQ	mount kit
OR-30	9' 9"	OCT	350 lbs.	titan base	(2) SBGC200SQ	mount kit
OR-30S	9' 9"	SQ	350 lbs.	titan base	(2) SBGC200SQ	mount kit
OR-40	13' 1"	OCT	500 lbs.	mount kit	titan base	(2) SBGC200SQ + (1) SBGC100SQ
GALAXY-35S*	11' 5"	SQ	n/a	mount kit	n/a	n/a
GALAXY-40S*	13' 1"	SQ	n/a	mount kit	n/a	n/a
GALAXY-50*	16' 4"	OCT	n/a	mount kit	n/a	n/a

Note: When stacking steel base weights, the SB50R and SB50SQ can only be used as the top weight.

* It is recommended that these items be mounted using our in-ground or concrete mount kits (see page 42).

OPTIONS

protective cover

Item	Item No.	MSRP
LIBRA-20S	CD951	-----
LIBRA-25	CD951	-----
LIBRA-25S	CD950	-----
ASTRAL-TC-35S	CD9004	-----
ASTRAL-TC-40S	CD9005	-----
ASTRAL-TC-50	CD9004	-----
ASTRAL-TC-50S	CD9005	-----
SR-27S	CD16A	-----
SR-30	CD16A	-----
SR-30S	CD16A	-----
SR-35	CD16A	-----
POLARIS-30S	CD36-02	-----
POLARIS-35S	CD36-02	-----
POLARIS-340RT	CD36-02	-----
POLARIS-40	CD36-02	-----
POLARIS-40S	CD36-01	-----
OR-27S	CD26A-1	-----
OR-30	CD26A-3	-----
OR-30S	CD26A-1	-----
OR-40	CD26A-1	-----
GALAXY-35S	CD46-1	-----
GALAXY-40S	CD46-3	-----
GALAXY-50	CD46-1	-----

specialty canopy

Item	Available Styles	MSRP
Valance	libra	-----
	astral-tc, sirius, polaris, orion & galaxy	-----
	astral-tc (5.0m) & galaxy (5.0m)	-----
Logo Printing	libra, astral-tc & polaris	Call for pricing
Designer Canopy	libra, astral-tc, sirius, polaris, orion & galaxy	Call for pricing

optional fabric

Optional Fabric	Price
Glen Raven FIRESIST®	Price Group 1 (+ 25%)



FIRESIST® awning fabric combines state-of-the-art flame retardant performance and UV resistance for the commercial awning, canopy and shade markets.



Logo on OR-30S

replacement canopy

Item No.	MSRP Price Group 1 Sunbrella® Awning Grade	MSRP Price Group 2 O'bravia® Awning Grade Sunbrella®/ Outdura®/ Bliss Furniture Grade
C-LIBRA-20S
C-LIBRA-25
C-LIBRA-25S
C-ASTRAL-TC-35S
C-ASTRAL-TC-40S
C-ASTRAL-TC-50
C-ASTRAL-TC-50S
C-SR-27S
C-SR-30
C-SR-30S
C-SR-35
C-POLARIS-30S
C-POLARIS-35S
C-POLARIS-340RT
C-POLARIS-40
C-POLARIS-40S
C-OR-27S
C-OR-30
C-OR-30S
C-OR-40
C-GALAXY-35S
C-GALAXY-40S
C-GALAXY-50

replacement frame

Item	Item No.	MSRP
LIBRA-20S	LIBRA-20S
LIBRA-25	LIBRA-25
LIBRA-25S	LIBRA-25S
ASTRAL-TC-35S	ASTRAL-TC-35S
ASTRAL-TC-40S	ASTRAL-TC-40S
ASTRAL-TC-50	ASTRAL-TC-50
ASTRAL-TC-50S	ASTRAL-TC-50S
SR-27S	SR-27S
SR-30	SR-30
SR-30S	SR-30S
SR-35	SR-35
POLARIS-30S	POLARIS-30S
POLARIS-35S	POLARIS-35S
POLARIS-340RT	POLARIS-340RT
POLARIS-40	POLARIS-40
POLARIS-40S	POLARIS-40S
OR-27S	OR-27S
OR-30	OR-30
OR-30S	OR-30S
OR-40	OR-40
GALAXY-35S	GALAXY-35S
GALAXY-40S	GALAXY-40S
GALAXY-50	GALAXY-50

FABRICS

stock fabrics

Price Group 1

Sunbrella®
Awning Grade
100% Solution-Dyed
Acrylic



4604 Natural



4642 Oyster



4683 Parchment



4644 Charcoal



4608 Black



4653 Mediterranean Blue
Tweed



4601 Pacific Blue



4666 Logo Red



4677 Tuscan

non-stock fabrics

Price Group 1

Sunbrella®
Awning Grade
100% Solution-Dyed
Acrylic



4634 White



4633 Linen



4628 Toast



4672 Heather Beige



4620 Beige



4676 Cocoa



4648 Taupe



4651 Silver



4630 Cadet Grey



4636 Storm

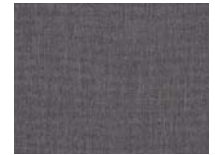

4615 Smoke



4684 Slate



4632 Ivy



4637 Forest Green



4671 Fern



4668 Aspen



4688 Basil



4600 Erin Green



4610 Turquoise



4612 Aruba



4664 Sea



4675 Capri



4624 Sky Blue



For more information refer to:



Shade Fabrics Swatch Card or visit www.sunbrella.com.

NOTE: Striped fabrics must be ordered in pairs, due to cutting requirements. Not available on POLARIS-340RT.

Price Group 2

Sunbrella®/
Outdura®/Bliss
Furniture Grade
100% Solution-Dyed
Acrylic



5404 Natural



5453 Canvas



7853 Tango Pearl



5422 Antique Beige



5476 Heather Beige



8318 Sesame Linen



5425 Cocoa



6461 Taupe



5488 Teak



40428 Cast Ash



14067 Mushroom



48135-02 Bliss Sand

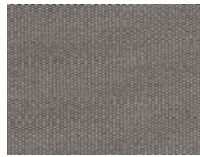

6457 Beacon Ash



40433 Cast Silver



48135-10 Bliss Pebble



14059 Haze



40434 Cast Slate

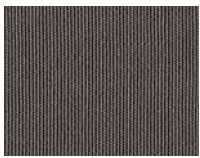

54048 Charcoal



5408 Black



48080 Spectrum Indigo



6439 Ink



48135-04 Bliss Onyx



5446 Forest Green



6463 Reseda

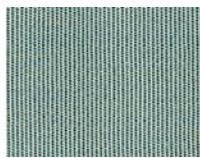

5413 Spa



54011 Ginkgo



5416 Aruba



6447 Surf



6407 Aquatic



40456 Cast Lagoon



5439 Navy



6433 Neptune



5401 Pacific Blue



48103S Cast Ocean



5403 Jockey Red



5407 Henna



5417 Tuscan



5438 Buttercup



7816 Tango Glacier



7825 Tango Truffle



7822 Mosaic Tile



40524-01 Trusted Fog Stripe



6661 Harper Putty Stripe



56079 Milano Char Stripe



6666 Paddock Aqua Stripe



6667 Kinzie Smoke Stripe



6668 Kinzie Coal Stripe



6703 Kinzie Rose Stripe



6711 Kinzie Grass Stripe



6733 Kinzie Royal Stripe



40524-02 Trusted Coast Stripe

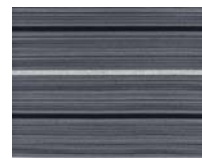

6662 Harper Steel Stripe



58039 Gateway Mist Stripe



6670 Reliant Coast Stripe



6669 Horizon Night Stripe

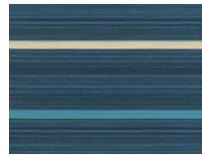

6660 Harper Ink Stripe

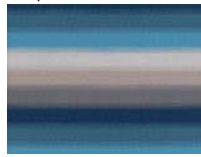

6664 Churchill Beach Stripe



56080 Milano Cobalt Stripe

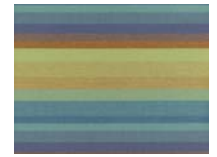

56096 Astoria Lagoon Stripe



56095 Astoria Sunset Stripe



6663 Harper Crimson Stripe



40584-01 Surround Dusk Stripe

NOTE: Striped fabrics must be ordered in pairs, due to cutting requirements. Not available on POLARIS-340RT.

Price Group 2
O'bravia®
Awning Grade
100% Solution-Dyed
Polyester



5804 Eggshell

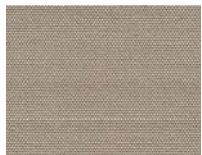

5822 Khaki



5825 Mocha



5827 Chocolate



5851 Fog

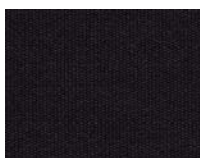

5808 Black



5839 Navy



5801 Cobalt



5816 Aqua



5850 Kiwi



5803 Red

NOTE: Fabric and finishes shown are not to scale. Colors may vary slightly from the actual fabric and finish; please refer to the actual fabric swatch and frame sample to view true color and detail.

FRAME FINISH COLLECTION



SS
Silver Shadow



UB
Urban Black
*Special Order**

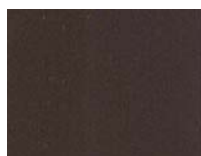

AB
Architectural Bronze
*Special Order**



AW
Arctic White
*Special Order**

Frame finish collection for umbrella styles only.

*Special order frame finishes have a minimum order quantity.

Contact your sales representative for more information and specific lead times.

Astral-TC available in Silver Shadow frame finish only.

PRODUCT SPECIFICATIONS

LIBRA

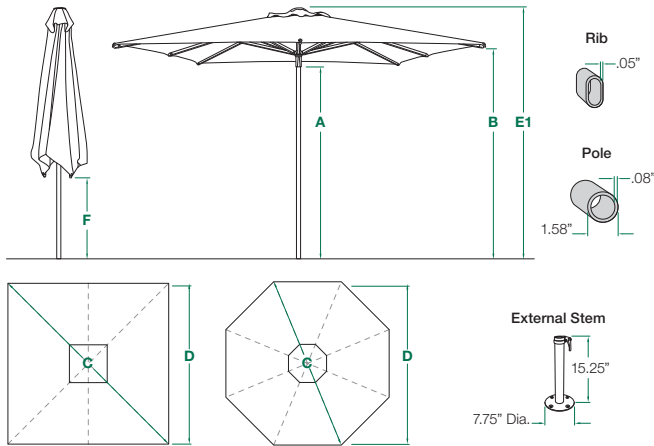

ASTRAL-TC

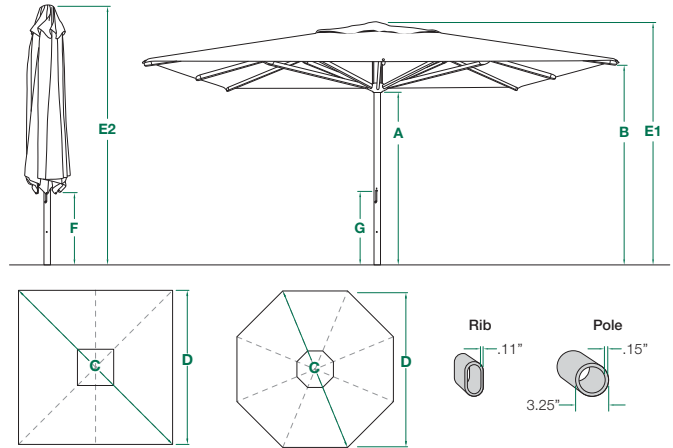

Key	Description	LIBRA-20S	LIBRA-25	LIBRA-25S	ASTRAL-TC-35S	ASTRAL-TC-40S	ASTRAL-TC-50	ASTRAL-TC-50S
	Canopy Shape	Square	Octagon	Square	Square	Square	Octagon	Square
	Coverage	43 sq. ft.	52 sq. ft.	67 sq. ft.	131 sq. ft.	172 sq. ft.	210 sq. ft.	266 sq. ft.
	Ribs	4	8	8	8	8	8	8
	Size	2.0m 6' 6"	2.5m 8' 2"	2.5m 8' 2"	3.5m 11' 5"	4.0m 13' 1"	5.0m 16' 4"	5.0m 16' 4"
	Weight	35 lbs.	40 lbs.	41 lbs.	159 lbs.	172 lbs.	165 lbs.	193 lbs.
A	Lower Hub HEIGHT (Open)	6' 1"	6'	6' 1"	7' 1"	7'	7' 1"	6' 8"
B	Rib End HEIGHT (Open)	6' 5"	6' 8"	6' 5"	7' 5"	7' 4"	7' 5"	7' 5"
C	Canopy LENGTH (Diagonal)	9' 1"	8' 1"	11' 5"	16' 2"	18' 6"	16' 4"	23' 2"
D	Canopy WIDTH	6' 6"	7' 6"	8' 2"	11' 5"	13' 1"	15' 2"	16' 4"
E1	Overall HEIGHT (Open)	7' 8"	7' 8"	8"	9' 2"	9' 4"	9' 2"	9' 6"
E2	Overall HEIGHT (Closed)	n/a	n/a	n/a	11' 5"	12'	12' 3"	13' 3"
F	Rib End HEIGHT (Closed)	3' 1"	3' 7"	2' 2"	3' 4"	2' 11"	3' 4"	1' 8"
G	HEIGHT to Crank Handle	n/a	n/a	n/a	2' 8"	2' 8"	2' 8"	2' 4"
	Min. Base Weight	100 lbs.	100 lbs.	100 lbs.	400 lbs.	500 lbs.	600 lbs.*	700 lbs.*
	MSRP Price Group 1 Sunbrella® Awning Grade	-----	-----	-----	-----	-----	-----	-----
	MSRP Price Group 2 O'bravia® Awning Grade Sunbrella® / Outdura® / Bliss Furniture Grade	-----	-----	-----	-----	-----	-----	-----

* Permanent mount recommended.

PRODUCT SPECIFICATIONS

SIRIUS

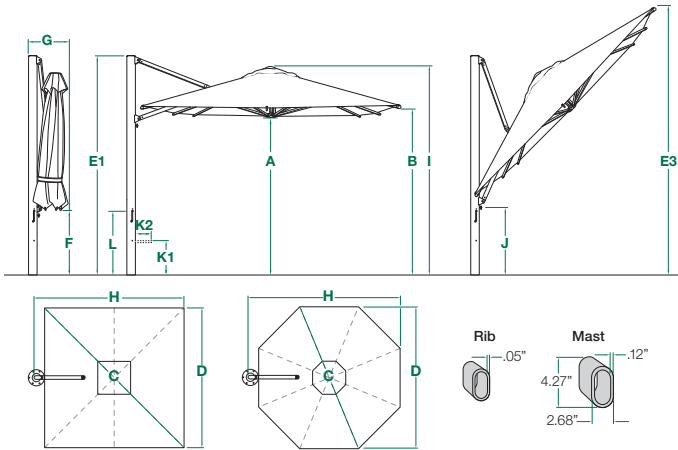

POLARIS

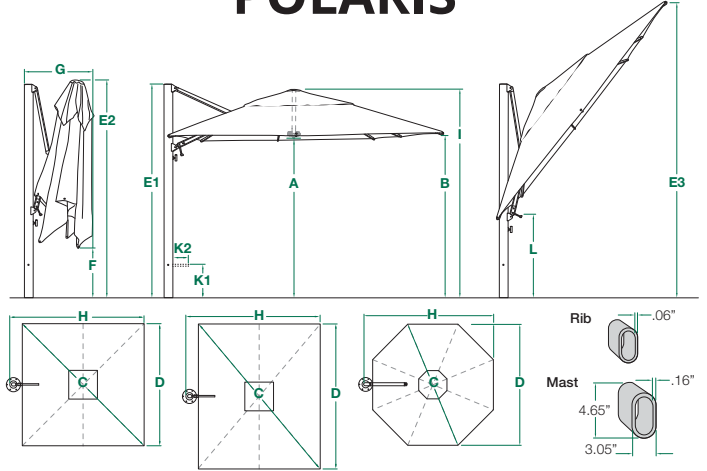

Key	Description	SR-27S	SR-30	SR-30S	SR-35	POLARIS-30S	POLARIS-35S	POLARIS-340RT	POLARIS-40	POLARIS-40S
	Canopy Shape	Square	Octagon	Square	Octagon	Square	Square	Rectangle	Octagon	Square
	Coverage	77 sq. ft.	75 sq. ft.	95 sq. ft.	103 sq. ft.	95 sq. ft.	131 sq. ft.	130 sq. ft.	134 sq. ft.	172 sq. ft.
	Ribs	8	8	8	8	8	8	8	8	8
	Size	2.7m 8' 9"	3.0m 9' 9"	3.0m 9' 9"	3.5m 11' 5"	3.0m 9' 9"	3.5m 11' 5"	3.0m x 4.0m 10' x 13'	4.0m 13' 1"	4.0m 13' 1"
	Weight	93 lbs.	87 lbs.	103 lbs.	92 lbs.	144 lbs.	149 lbs.	151 lbs.	158 lbs.	159 lbs.
A	Lower Hub HEIGHT (Open)	6' 4"	6' 6"	6' 3"	6' 8"	7'	7' 6"	7' 2"	7' 4"	7' 8"
B	Rib End HEIGHT (Open)	6' 8"	6' 11"	6' 8"	7'	7'	7' 3"	7' 5"	7' 3"	7' 3"
C	Canopy LENGTH (Diagonal)	12' 6"	8' 10"	13' 11"	10' 2"	13' 11"	16' 3"	16' 4"	12' 6"	18' 7"
D	Canopy WIDTH	8' 9"	9' 9"	9' 9"	11' 5"	9' 10"	11' 6"	9' 10" / 13' 1"	13' 1"	13' 1"
E1	HEIGHT to Mast Top	8' 9"	8' 11"	9'	8' 11"	9' 2"	9' 5"	9' 6"	9' 7"	9' 6"
E2	Overall HEIGHT (Closed)	n/a	n/a	n/a	n/a	9' 4"	9' 6"	9' 6"	9' 11"	10' 2"
E3	Overall HEIGHT (Max Tilt)	13' 9"	12' 5"	14' 7"	12' 11"	13' 1"	13' 10"	13'	15' 1"	15' 3"
F	Rib End HEIGHT (Closed)	2'	3' 5"	1' 7"	2' 10"	2' 4"	1' 4"	1' 4"	3' 4"	1' 1"
G	Mast End to Canopy Edge (Closed)	1' 8"	1' 8"	1' 8"	1' 8"	1' 7"	1' 7"	1' 7"	2'	1' 8"
H	Mast End to Canopy Edge (Open)	9' 11"	10' 5"	11'	11' 9"	11'	12' 9"	11' 2"	13' 11"	14' 3"
I	HEIGHT to Canopy Top (Open)	8' 5"	8' 5"	8' 5"	8' 5"	8' 8"	9' 3"	9' 2"	9' 4"	9' 8"
J	HEIGHT to Slider Car (Max Tilt)	3' 1"	3' 2"	3' 1"	2' 10"	n/a	n/a	n/a	n/a	n/a
K1	HEIGHT to Turning Handle	1' 9"	1' 9"	1' 9"	1' 9"	1' 7"	1' 7"	1' 7"	1' 7"	1' 7"
K2	Turning Handle Width	9.5"	9.5"	9.5"	9.5"	11.5"	11.5"	11.5"	11.5"	11.5"
L	HEIGHT to Crank Handle	2' 11"	2' 11"	2' 11"	2' 11"	3' 11"	3'	3' 8"	2' 11"	3' 8"
	Min. Base Weight	350 lbs.	350 lbs.	350 lbs.	450 lbs.	450 lbs.	550 lbs.	550 lbs.	700 lbs.*	700 lbs.*
	MSRP Price Group 1 Sunbrella® Awning Grade	-----	-----	-----	-----	-----	-----	-----	-----	-----
	MSRP Price Group 2 O'bravia® Awning Grade Sunbrella® / Outdura® / Bliss Furniture Grade	-----	-----	-----	-----	-----	-----	-----	-----	-----

* Permanent mount recommended.

PRODUCT SPECIFICATIONS

ORION

GALAXY

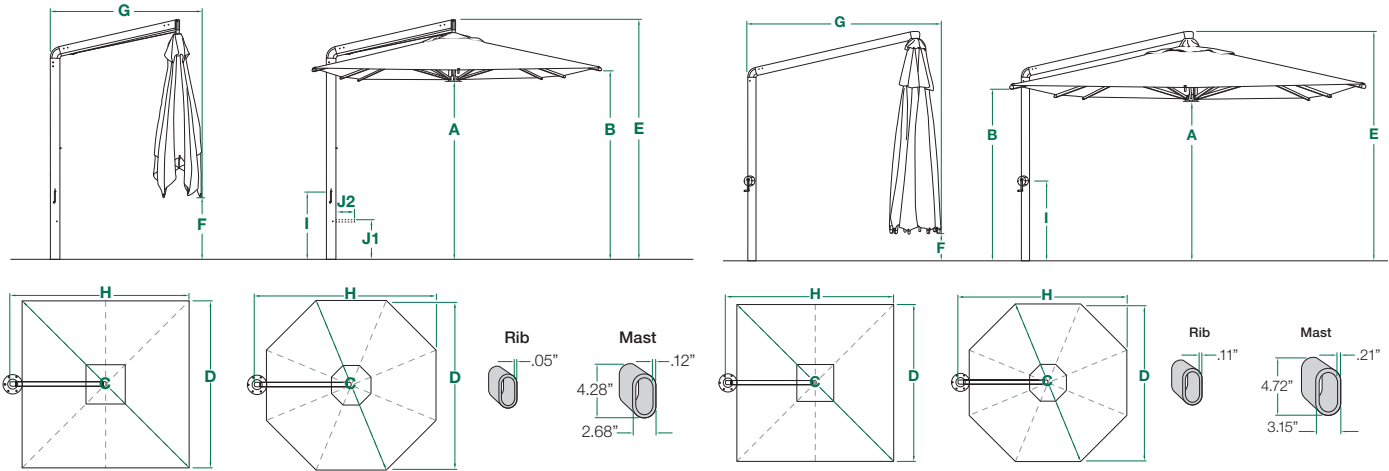

Key	Description	OR-27S	OR-30	OR-30S	OR-40	GALAXY-35S	GALAXY-40S	GALAXY-50
	Canopy Shape	Square	Octagon	Square	Octagon	Square	Square	Octagon
	Coverage	77 sq. ft.	75 sq. ft.	95 sq. ft.	134 sq. ft.	131 sq. ft.	172 sq. ft.	210 sq. ft.
	Ribs	8	8	8	8	8	8	8
	Size	2.7m 8' 9"	3.0m 9' 9"	3.0m 9' 9"	4.0m 13' 1"	3.5m 11' 5"	4.0m 13' 1"	5.0m 16' 4"
	Weight	103 lbs.	94 lbs.	108 lbs.	104 lbs.	259.42 lbs.	273.42 lbs.	265.37 lbs.
A	Lower Hub HEIGHT (Open)	6' 8"	6' 7"	7'	7' 1"	7' 6"	7' 1"	7' 5"
B	Rib End HEIGHT (Open)	6' 9"	7'	6' 11"	7' 4"	7' 11"	7' 5"	7' 6"
C	Canopy LENGTH (Diagonal)	12' 6"	9' 9"	13' 10"	13' 1"	16' 5"	18' 8"	16' 4"
D	Canopy WIDTH	8' 9"	8' 8"	9' 9"	11' 8"	11' 7"	13' 3"	15' 6"
E	Overall HEIGHT	9' 3"	8' 11"	9' 7"	9' 10"	10' 1"	9' 10"	10' 2"
F	Rib End HEIGHT (Closed)	2' 4"	3' 6"	1' 9"	2' 6"	1' 4"	9"	1' 2"
G	Mast End to Canopy Edge (Closed)	5' 9"	5' 4"	6' 2"	7' 3"	7' 9"	7' 8"	8' 3"
H	Mast End to Canopy Edge (Open)	9' 6"	9' 4"	10' 6"	12' 3"	12' 11"	14' 6"	16' 6"
I	HEIGHT to Crank Handle	3' 1"	3' 1"	3' 1"	3' 1"	3' 1"	3' 1"	3' 1"
J1	HEIGHT to Turning Handle	1' 9"	1' 9"	1' 9"	1' 9"	n/a	n/a	n/a
J2	Turning Handle to WIDTH	9.5"	9.5"	9.5"	9.5"	n/a	n/a	n/a
	Min. Base Weight	350 lbs.	350 lbs.	350 lbs.	500 lbs.	Mount	Mount	Mount
	MSRP Price Group 1 Sunbrella® Awning Grade	-----	-----	-----	-----	-----	-----	-----
	MSRP Price Group 2 O'bravia® Awning Grade Sunbrella® / Outdura® / Bliss Furniture Grade	-----	-----	-----	-----	-----	-----	-----

NOTE: It is imperative that the eight (8) spacer buttons (white plastic cups/screws) are installed after the canopy is opened for the first time.

"Quick-Ship" program is available in select awning grade fabrics on our 8'2" Libra styles and accessories.

Program is available year-round & ships within
5 BUSINESS DAYS* in the continental U.S.

*NOTE: Shipping may be delayed due to possible fabric shortage.

LIBRA

Available frame finish:



Silver Shadow

See pages 42-44 for Libra base/
mount options. (sold separately)

VALANCE OPTION NOT AVAILABLE.

LIBRA-25
8'2" Octagon



LIBRA-25S
8'2" Square



 **Awning Grade** 100% Solution-Dyed Acrylic



4601 Pacific Blue



4604 Natural

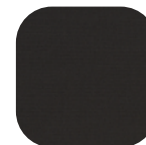

4608 Black



4644 Charcoal



4666 Logo Red



4677 Tuscan

ACCESSORIES



The "Quick-Ship" Program also includes the following accessories:

- Umbrella bases
- Mount kits
- Protective furniture covers

As a condition of doing business with Treasure Garden, Inc. and its affiliates (hereinafter, "TG") all persons involved in the commercial purchase, sale, or resale of TG products (each, a "Dealer") shall be bound by the following terms and conditions (the "Agreement").

Distribution:

To qualify as an authorized TG retail Dealer a business must:

- Have a permanent store-front retail business location with reasonable space to display TG products and accessories.
- Maintain an inventory of TG merchandise throughout their outdoor product selling season.
- Reasonably accommodate purchases of anyone showing interest in TG products.
- Be moderately capable of "after the sale" service and support to the end-user and reasonably accommodating of consumer requests for such service and support.
- Retail Dealers should be qualified or trained by their TG sales representative.

TG reserves the right to respond to geographic and individual market and competitive situations by applying different policies to its various Dealers. TG also reserves the right to rescind or modify, in its sole and absolute discretion, any existing or future sales program or policy, or the credit terms (if any) extended to a Dealer. In addition, TG may terminate any authorized Dealer, for any reason or no reason, in its sole and absolute discretion and without notice.

Prices:

Prices listed in the catalog are suggested retail prices. A Dealer's cost is based on the designated Dealer classification. Ask your Sales Representative for details regarding TG's 2022 programs and pricing structure.

Taxes and Surcharges:

The Manufacturer's Suggested Retail Price ("MSRP") does not include any state tax, local tax or surcharges. California sales tax may apply to shipments made within California, picked up at our California facility or drop shipped within the state of California unless we have a CA resale certification on file. For shipments out of CA the appropriate sales taxes will be added to acknowledgements or invoices unless we are provided with a valid State sales tax exemption certificate. Sales taxes will be added based on the address where the product is being shipped to. We collect sales tax in our nexus states, as of January 2020 our nexus states are AR, AZ, CA, CO, CT, FL, GA, IA, ID, IL, IN, KY, LA, MA, MD, ME, MI, MN, MO, NC, NE, NJ, NM, NV, NY, OH, OK, PA, RI, SC, TN, TX, UT, VA, WA & WI. Please note that CA, MA & MI will not accept another states resale certification or resale number for tax exempt purposes.

Order Acceptance:

We accept orders from an authorized retail Dealer or contract accounts only. Ask your sales representative for details on becoming an authorized retail Dealer or contract account. If you place an order with Treasure Garden and you or your designee accepts delivery of any goods in relation to the order (whether or not you believe the delivery conforms with the order) you will be bound by the terms and conditions of our 2022 catalog.

If you do not accept all of the Catalog Terms you must notify us in writing within 10 days of receiving your acknowledgement or the goods, whichever occurs sooner, to cancel or return the order at your expense. If you fail to do so, you will be bound by the Catalog Terms. In the event of a conflict between the terms on any purchase order, invoice, acknowledgement, or other document and the Catalog Terms, the Catalog Terms will prevail.

Order Policy:

To ensure that your order is processed without delay we require:

- A written purchase order (no phone orders) from an authorized Dealer including the business name, account number, phone number and purchase order number.
- Ship date and specific shipping instructions. If you request freight collect or 3rd party billing, please provide the account number.
- Our item/style number, fabric number, type and color.
- Quantity of each style.
- Customer's name on all Special Orders.
- Order type: For Quick-Ship items (pg. 55), use order code: **TGEX**

NOTE: Dealers who place a single purchase order without specifying a specific program, the order will automatically be shipped out at the longer lead time based on the items ordered. Dealers who want separate shipments with different lead times (i.e. – Quick-Ship and Custom), please write separate purchase orders per program and make sure correct items are offered in those programs. Dealers who place a single purchase order specifying multiple or incorrect programs based on items ordered, the order will automatically be split-shipped

separately according to their respective programs.

A 50% deposit may be required for orders that contain custom, non-stock fabrics, or large quantities. The deposit must be made before the order is scheduled into our system.

Please note that any discrepancies in your purchase order can cause significant delays. You must review the acknowledgment for accuracy and advise TG immediately of any discrepancies or changes. Lead time starts once order is finalized.

Changes/Cancellations:

No cancellations, changes, additions or holds will be accepted for an order for which materials have been ordered or produced. Cancellations and/or changes of product or shipping dates on custom orders must be received in writing within 3 business days of the acknowledgement date. Order revisions will no longer be accepted for Quick-Ship if the order has already been processed in the system or after 24 hours, whichever occurs first. No cancellations or revisions will be accepted after 72 hours for non-stock fabric orders. NO EXCEPTIONS. Orders that do not follow these guidelines will be charged a 25% re-stocking or handling fee. We cannot guarantee that purchase orders added to an existing order will be shipped together. If items are added to an order or an item on an order is changed, the entire order may be rescheduled as of the date of the change. This may result in a later ship date than the original order. In the event an order is refused and returned to us, a 25% restocking/handling fee may be assessed in addition to the inbound and outbound freight charges. The 25% restock fee also applies to pro forma orders that are cancelled due to nonpayment.

Container Orders:

Due to the special pricing on container orders, all containers must be prepaid via wire transfer or paid by letter of credit. If you have not placed a prior container order or if there were previous payment delays or if there are non-stock/custom items on the order, we may require a 50% deposit before we start manufacturing the order. The remaining balance will be due two weeks before the order is shipped. The purchase of a container may also involve bank charges and other charges unrelated to the price of the product including but not limited to duties, storage, shipping and transportation charges, third party inspection charges whether inspected at point of origin, point of entry or point of delivery. Once your purchase order is sent in, we start reviewing and scheduling your order into our production schedule. It is important that you inform the Baldwin Park office of any order changes within 10 business days from when your order is sent in. After reviewing your purchase order, we will mail or fax an order acknowledgement with your payment instructions.

We must be informed of any discrepancies or revisions to CONTAINER ORDERS in writing within 10 business days of sales order acknowledgment date. No cancellations are allowed. When placing orders, please be mindful of Chinese New Year. Generally, our manufacturing schedule is tight around that time.

Back Order/Partial Shipments:

Due to the considerable number of items we offer, we may not initially be able to ship or deliver your entire order. In such event the balance and/or entire order thereof will be back-ordered and shipped and delivered at a subsequent time or times. Standard shipping charges will apply to partial or back order shipments.

Lead Times:

Our goal is to ship custom in stock fabric orders within 6-8 weeks of the acknowledgement of the order, 8-10 weeks for non stock fabrics.

Notwithstanding anything to the contrary herein, TG does not guarantee that any shipments of any type of product or order will be delivered at or before a date certain. All large quantities may result in partial shipments. This is a goal – not a guarantee – and may be slightly affected by availability of fabrics & consumer demands.

ALL SHIPMENTS - TG shall, in the event of no routing instructions from the buyer; select a carrier, which it feels, in its sole discretion, can adequately handle each shipment.

Order Scheduling:

Deliveries are subject to fire, storm, flood, war, rebellion, riot, strike or labor trouble, interruptions to transportation, perils of navigation, damage to factory, equipment of facilities, governmental mandates, including the exercise of acts of God, failure of our sources of supply in whole or in part, and other cause beyond our control. We shall not be liable for any damages or failure to deliver or delay in delivery due to any such causes. If possible we will attempt to ship

merchandise the week of the requested ship dates.

However, in order to maintain an orderly schedule, we reserve the right to schedule the merchandise shipment to the nearest available production schedule and to ship accordingly.

Our regular business days are Monday through Friday.

Freight Charges:

The shipping charges on your invoice may differ from those on your acknowledgement. This is largely due to instability in today's fuel economy. Please understand that these charges are assessed by the carrier, not TG. These charges can sometimes include fuel surcharges, lift gate, extra delivery charges, as well as standard pallet fees and box pallet fees which may not have been indicated on the preliminary freight quotes. The pallet fees may increase depending on the cost of these items.

If the freight charges are prepaid & added to your invoice, the shipping charges may include any applicable pallet charges. To ensure the most economic freight for our customers, we are constantly reviewing freight rates. If we ship your orders freight collect or 3rd party billing we will bill your company for any applicable pallet charges.

Freight Claims:

All merchandise is delivered to the carrier in factory new condition. Our FOB shipping points are Baldwin Park, CA or Ningbo, China. The FOB location depends on your order type and product availability. The carrier accepts responsibility for the safe delivery upon acceptance of the shipment.

TG should be notified immediately regarding any claims. Claims for loss or damage sustained in transit must be filed by the Dealer, as follows:

Visible Damage:

It is the Dealer's responsibility to check the merchandise and file a claim with the carrier if the shipment was made using the dealer's carrier and account. Request a claim form from the delivering carrier and file your claim immediately. If the shipment was made using TG's carrier and account, it is the Dealer's responsibility to check the merchandise and notify TG immediately of the situation so that a claim can be filed. In either situation, make a notation on the Bill of Lading as to the nature and extent of the damage and obtain a signature of the carrier's agent. (Failure to adequately describe this information may result in the carrier refusing to honor the claim and TG will not, under any circumstances, be liable for damage sustained in transit).

Concealed Damage:

If damage is discovered when unpacking the merchandise, immediately mark the damaged area and submit a written request for the carrier to inspect. Attach a copy of the concealed damage information. Do not remove the merchandise from the original carton until the carrier inspection is complete. If the merchandise was shipped using TG's carrier and account, it is the Dealer's responsibility to notify TG immediately of the situation so that a claim can be filed. Concealed damage needs to be reported and claim filed within 5 days for all carriers.

Shortage:

It is the Dealer's responsibility to inspect all merchandise and to file claims with the carrier in the event of product shortage. Make a notation on the Bill of Lading as to the number of cartons short. TG must also be notified immediately of any shortages. File the claim with the delivery carrier immediately. No claim for shortages, damaged items or errors will be honored unless it is made in writing on the Bill of Lading immediately upon receipt of the shipment. Notwithstanding anything to the contrary in this Agreement, failure to make a claim on the Bill of Lading will constitute a waiver of any rights to a refund or credit.

Return Goods:

No returns will be accepted without a written Return Authorization (RA#) from the factory. A request for return must be done within 30 days of delivery and all RA's are valid for 60 days. It is the Dealer's responsibility to follow routing instructions. Please fax in a request for an RA#. Your request must include the following information:

- Company name, contact name, number & store hours;
- The TG invoice and/or acknowledgement;
- The item no., number of units to be returned and carton total;
- The reason for the return; and
- Which carrier will be returning the goods and the date of the shipment.

Any item that is returned for credit that is not under TG's warranty policy is subject to a 25% restocking fee (and must be properly packaged) plus inbound and outbound freight charges, if applicable. Any item that is returned for repair or replacement that is not under TG's warranty policy is subject to the applicable repair charges listed in the "Other Fees" section, below. FOR FULL CREDIT CONSIDERATION, RETURNED MERCHANDISE MUST BE BOXED & IN NEW CONDITION. TG will only organize the return of product for warranty determination from the original point of shipment within the US and Canada.

Per the Treasure Garden Limited Warranty, Treasure Garden restricts warranty service for TG products to the country where Treasure Garden or its authorized TG retail Dealers originally sold the product.

Errors:

There may be errors in the prices, descriptions or images of certain merchandise in our catalog or sales material. We reserve the right to restrict orders of those items.

Other Fees:

These fees apply to both contract accounts and retail Dealers.

- Non-warranty repairs are subject to a labor charge of \$35 per hour plus applicable parts, inbound and outbound freight charges. Please allow at least 5 business days for processing.
- A \$15 handling fee will be added to any purchase under \$50. To avoid this fee, please accumulate your product needs and place orders together. DOES NOT APPLY TO PARTS, FABRIC BY THE YARD OR DISPLAY STANDS.
- A \$15 drop shipment fee will be added to drop shipment orders. We can drop ship orders to US addresses only. The appropriate sales and use tax will be added to the orders unless we have a resale certification for the state that the items are being shipped to. Depending on the item, additional delivery charges may apply. TG reserves the right to rescind or modify, at its sole discretion, drop shipments or the drop shipment of specific items.
- A \$25 service charge will be assessed on any returned check.
- Residential delivery fees, lift-gate fees, limited access and "call before delivery" fees vary depending on the carrier.
- A Materials Handling Fee may be assessed for palletized orders shipping LTL freight collect or when special labels are required to print for each order.

Shipping:

Most TG products can be shipped using parcel companies (UPS, FedEx or other). Some of our larger or heavier products however, must be shipped with a trucking company. Such products are identified with the "Truck Only". TG can only ship to addresses in the US and Canada. If shipping to Canada, you must have your own broker to clear items through customs and this information must be provided with the purchase order.

Treasure Garden Storage Policy:

We reserve the right to assess storage fees if you are not able to receive the product when Treasure Garden is ready to ship, your carrier does not pick up within 3 days of notification that the shipment is ready or after a 3-day grace period*. The grace period starts the day after the original Estimated Ship Date on your Order Acknowledgement (or the date the product is ready to ship). When the grace period expires, the following storage policy and pricing will be applied:

- Un-palletized orders are \$50 per day*
- Palletized orders are \$50 per day*; plus an additional \$20 per pallet

*All time frames referenced in policy are business days

† Customer is responsible for all shipping charges if they are unable to receive shipment when carrier is ready to deliver. This includes but is not limited to, storage and re-delivery fees.

†† Storage is not available for Cash In Advance customers.

Payments:

Payment will be accepted in US Dollars only. If a deposit or pre-payment is paid by a standard business check drawn on a domestic banking institution, please allow 2-5 business days from TG's deposit date for your funds to clear. If paid by a standard business check drawn on an International banking institution, please allow 4-6 weeks from TG's deposit date for your funds to clear. If your deposit is prepaid via wire transfer, please allow 1 business day for your funds to clear. Invoice payments should be sent to be received on or before the due date at our corporate office in Baldwin Park, CA at the address in the "Notices" section, below. Payments made in a different manner may be delayed.

Pricing:

"MSRP" means the Manufacturer's Suggested Retail Price as set forth in this Catalog. "MAP" means the Minimum Advertised Price as set forth in this paragraph. Dealers must adhere to MAP requirements when advertising via any traditional media, in all online advertising, online comparison price shopping, and landing pages. Dealers cannot advertise TG products below a published Net MAP price list effective the start of each fiscal year. TG reserves the right to adjust MAP pricing based on MSRP and/or MSRP pricing, changes due to tariff implementation and/or other unforeseen market conditions, as needed during the fiscal year. This net pricing is inclusive of, but not limited to, discounts such as coupons, promo codes, email "sign up" discounts and sales tax. In addition, no advertisements may state or otherwise suggest that the TG MSRP is higher than the actual MSRP as set forth in this catalog. It is also incumbent on all dealers to update their pricing July 1, 2021 for 2022 season to reflect any changes to MSRP and MAP that might occur. MAP Policy may vary for international dealers, please see your local sales representatives for details.

Minimum Advertised Price Requirements:

As in any Minimum Advertised Price ("MAP") program, the intent is to uphold the integrity of the Treasure Garden line of products and protect the investments

made by Treasure Garden and its Dealers and retail partners. Violating MAP requirements only serves to devalue the brand in the eyes of the consumer. These MAP requirements apply to any Dealers advertising TG products via traditional media including, but not limited to, newspapers, mailers, inserts, circulars, magazines, catalogs, television and radio. In addition, the MAP requirements apply to any Dealers selling or advertising TG products online and/or having a checkout/cart system.

MAP Policy Violation Enforcement:

TG reserves the right to determine, in its sole and unfettered discretion, whether a violation of the MAP requirements has occurred. If TG determines that a Dealer has violated the MAP requirements, TG may, in its sole and unfettered discretion, terminate its relationship with the Dealer without notice or an opportunity to cure. The Dealer agrees that money damages or other legal remedies would not, standing alone, be a sufficient or adequate remedy for any breach or violation of the MAP requirements. As such, in addition to all other remedies available to TG, TG shall be entitled to an injunction restraining such breach or violation and to other equitable relief, including specific performance, without a bond or other security being required.

Product Advertising:

All TG products advertised may include the Treasure Garden name in the product description. Product advertising may include proprietary names (e.g., O'bravia®, Solefin®, etc.) and the Treasure Garden logo in product descriptions. Product names cannot be changed without prior approval (e.g. EVO, Polaris, etc.). Dealers may use their own images of TG products that they have taken themselves OR use images offered in TeamTG. Treasure Garden logos and logos of proprietary products will be provided on TeamTG. Lifestyle images provided by Treasure Garden should not be altered without prior approval. The Dealer's permission to use the Treasure Garden brand, tradenames, logos, images, and any intellectual property is subject to the Dealer's strict compliance with this Agreement including, but not limited to, the MAP requirements.

Bulk Sale Restrictions:

If a Dealer decides to resell product to a third party said Dealer is responsible for any warranty or service issues, as well as is still bound to this agreement. The third party is not under agreement with TG, it is the Dealer that is doing business with TG.

Duty to Notify TG of Complaints:

Dealers shall make a careful and thorough inspection of all goods received. Subject to and without limitation of the requirements of the "Freight Claims" section above, Dealers must notify TG in writing of any complaints or issues, whether existing or reasonably foreseeable, relating to TG's performance including, but not limited to, discrepancies in quantity or description of items delivered, defects or potential defects in items delivered, or any other issue whatsoever relating to TG's performance (except issues relating to billing disputes, which are dealt with in the next section.) Notice shall be provided to TG within 30 days of:
(i) the Dealer's receipt of any defective or non-conforming goods, or (ii) the time any other issue complained of came, or should, with reasonable care, have come to Dealer's attention – whichever is earlier. Unless timely notification is received by TG in accordance with the terms hereof, which notice shall identify with particularity all complaints or issues asserted by the Dealer, the Dealer irrevocably waives any and all complaints relating to any defective or non-conforming product or any other issue whatsoever relating to TG's performance and the Dealer shall have no recourse against TG. The Dealer shall be solely responsible for retaining proof that the written notice required by this section was received by TG.

Payment Obligations:

Dealers agree to examine immediately upon receipt each of TG's statements of account, invoices, or other billing statements (collectively, "Bills"), and to notify TG in writing of any disputed Bills within 10 days of receipt. Such disputes may include, but are not limited to, disputes relating to charges for items that were billed but not received; charges for product that was received but not ordered; or charges for items that were returned, refused, credited, or have a freight claim pending. Dealers will not withhold payment when disputes arise. Only the disputed portion of a timely disputed past-due balance may be withheld. Unless timely notification is provided to TG in accordance with the terms hereof, which notice shall identify with particularity any and all objections to any of TG's Bills, the Dealer irrevocably waives any and all objections to TG's Bills. In addition, the Dealer agrees that its obligation to pay TG is separate and independent from any obligations TG may have to the Dealer. In the event the Dealer fails to pay TG in accordance with the terms hereof, the Dealer irrevocably waives the right to assert any and all claims, offsets, or any other defenses whatsoever to TG's right to payment. The Dealer further agrees that any payments to TG may be applied to any invoices or other indebtedness owed to TG, in TG's sole and absolute discretion. The Dealer shall be solely responsible for retaining proof that the written notice required by this section was received by TG.

Statements are sent on the 1st business day of each month.

Attorneys' Fees:

The Dealer agrees that it shall be liable for all of TG's attorneys' fees (including local counsel fees), experts' fees, accountants' fees, court fees, collection costs, collection agency fees (if applicable), and any other expenses, whether or not incurred in connection with litigation or arbitration, arising from the breach of any term of this agreement by the Dealer, and/or in connection with the enforcement of any judgment or award rendered in favor of TG.

Governing Law:

You agree that all matters relating to your purchase and use of TG products, including all disputes, will be governed by the laws of the United States and by the laws of the State of California without regard to its conflicts of law provisions. You agree to the personal jurisdiction by and venue in the state and federal courts in Los Angeles County, California, and waive any objection to such jurisdiction or venue.

No Waiver:

None of TG's rights hereunder will be deemed to be waived or modified in any way based upon the manner in which this Agreement is performed or TG's failure to enforce its rights hereunder or insist on strict and timely performance of the Dealer's obligations. Without limitation to the foregoing, acceptance of payment outside of the stated credit terms shall not operate as a waiver of the stated credit terms.

Limitation on Liability:

In no event will TG be liable to the Dealer for any lost profits, lost savings, or any consequential, incidental or special damages arising out of or in connection with the parties' relationship, even if TG has been put on notice of the possibility of such damages. Without limitation to the foregoing, under no circumstances will TG be liable to the Dealer for punitive damages.

Disclaimer:

Please note that TG, reserves the right to alter or modify product styles and to discontinue frames and fabrics without notice. For more information about TG products, please contact us at: (626) 814-0168 or email: info@treasuregarden.com

Notices:

All written notices required hereunder shall be ineffective unless sent to the following addresses by Federal Express and email:

info@shademakerusa.com – and – Shademaker
13401 Brooks Drive
Baldwin Park, CA 91706

Headings:

Section headings are inserted for ease of reference only and shall have no effect on the interpretation of this agreement.

MAINTENANCE

maintaining the shademaker frame and fittings

1. Hose mast and frame with water periodically, more often if installation is in a salty or industrial environment.
2. Inspect the installation fitting, mount bolts, rib spacers, etc. on a regular basis and tighten if necessary.

maintaining the shademaker canopy fabric

1. Clean up spills and stains right away. Spills can be removed by using a clean absorbent cloth.
2. For general maintenance, use a soft brush to remove dust and dry soil. Wash down with clean, warm water (i.e., garden hose) every so often to avoid dirt becoming ingrained. Allow the fabric to air dry before closing the canopy.
3. If a thorough cleaning is necessary, sponge over the fabric using a mild soap solution (2% solution). Rinse well with plenty of water to remove all soap residue.
4. Never use detergents, cleaning fluids or solvents. Grease and oil stains may be removed by using turpentine or similar with an absorbent cloth.
5. Please visit the fabric websites for more details: www.shademakerusa.com or www.sunbrella.com
6. Use protective canopy cover during storage or when not in use.

mark-off/crazing fabric

NOTE: Sunbrella Awning/Marine fabric is treated with a finish which gives the fabric its water repellency and a firmer hand which helps in the sewing and fabrication of the products. Mark-off/Crazing may appear as white scuff marks or thin white lines on the fabric which will normally diminish or go away with normal weathering and will not affect the overall performance of the product.

WARRANTY

Shademaker manufactures all its shade styles from the finest aluminum alloys to ensure the strength, durability, and integrity of each and every style. We pride ourselves as a totally vertical operation. This means that we manufacture and produce over 90% of the components used in our products from the raw state. We can monitor every stage of the manufacturing process and maintain a consistent level of quality.

Our only business and focus is shade and shade type products. Our goal is that each and every Shademaker style will exceed your expectations at a competitive price that will make you smile.

NOTE: Wind damage is not covered under any manufacturer's warranty.

Our umbrellas are serviceable, meaning that parts can be ordered under warranty at no charge, if found that the damage is a manufacture defect and/or purchased out of warranty to make them whole again.

5 Year Limited Warranty includes the LIBRA, ASTRAL-TC, SIRIUS, POLARIS, ORION and GALAXY styles. This includes the mast, boom, head fitting, elbow, center pole/sidepost, arms, ribs, upper and lower hub, and stainless steel hardware only. If there is damage under the warranty, Shademaker will replace and/or repair any item listed in this category at its discretion. Labor charges are not covered under this limited warranty.

5 Year Limited Warranty applies to Glen Raven FIRESIST® and Sunbrella® furniture grade, and O'bravia® awning grade fabrics. Labor charges are not covered under this limited warranty.

10 Year Limited Warranty includes the Sunbrella awning & marine grade Fabric Collection. Visit www.sunbrella.com/warranty for more details. Labor charges are not covered under this limited warranty.

1 Year Limited Warranty covers base wheels and the powder coat finish on all bases. If the powder coat finish flakes, bubbles, peels or loses color; Shademaker will re-finish or replace the defective bases at its discretion. Normal wear and tear is not covered under this limited warranty. Labor charges are not covered under this limited warranty.

1 Year Limited Warranty covers accessories and protective covers.

What Is NOT Covered: Failure caused by unreasonable or abusive use, or failure caused by neglect of reasonable and necessary care, and any modification to product are not covered by this warranty. Additionally, acts of nature (including but not limited to wind, hurricanes, tornadoes, and storms) are not covered by

this warranty. This warranty covers return freight of any warranted product only for the first year. This warranty gives you specific legal rights and you may have other rights which vary from state to state. Any Shademaker Galaxy styles that do not have spacer buttons installed are not covered by this warranty. Closeout and promotional items sold by the dealer as is are not covered by this warranty.

Wind Damage: Shademaker highly recommends that no umbrella, regardless of size or weight, ever be left unattended in the open position. In windy conditions, it is further recommended that umbrellas be closed, removed from their base, and stored or laid horizontally. This will reduce the risk of personal injury, damage to your umbrella, furniture, and other belongings or property. To ensure stability of your umbrella, please observe proper placement, and use sufficient base weight. This catalog contains minimum recommendations for necessary weight for each style. Keep umbrella properly secured to umbrella base at all times. Thoroughly read and follow all provided instruction manuals.

Sufficient base weight must be used to secure umbrellas at all times. Please see individual product pages for recommended minimum weight requirements for free-standing applications. Using a Shademaker mount kit is always the preferred method of securing your umbrella above all other methods. We recommend a licensed contractor to secure your Shademaker umbrellas.

Caution: Seaside and indoor pool use, salt & chlorides can accumulate on the powder coat finish, leading to finish failure. Failure or neglect to make needed cleanings may cause paint to blister, and such failure will void limited warranty.

Irregularities in Production Process: The possibility of "Irregularities" in the product surface may occur during the production process. However, these irregularities do not reduce the quality of the product. Shademaker monitors every stage of production to ensure a clean and consistent appearance on every part.

Rust: Rust is a natural part of the aging process of all steel based materials and is therefore NOT considered a defect. Steel plate bases are designed to require minimum maintenance. Bases should be kept clean. Do not let dirt build up on the bases. Never leave bases standing in water. To keep your bases looking their best, you may wish to store them when not in use for an extended period of time.

International Returns: If an item is found to be under warranty Shademaker shall only be responsible for ground shipping charges to the location of the product within the continental United States and Canada. Any duties, express, international or special shipping charges are at the expense of the retail dealer or consumer.

IMPORTANT RESTRICTION FOR SM PRODUCTS WARRANTY SERVICE: Shademaker restricts warranty service for SM products to the country where Shademaker or its authorized SM retail Dealers originally sold the product.

Changes/Cancellations: No cancellations, changes, additions or holds will be accepted for an order for which materials have been ordered or produced. Cancellations and/or changes of product or shipping dates on orders must be received in writing within 5 business days of the acknowledgment date. Orders that do not follow these guidelines will be charged a 25% restocking or handling fee. Specially ordered merchandise and custom logo products cannot be cancelled, returned, or refunded. Delivery dates on custom orders are estimated only and may change because of fabric, shortages, production delays, port delays, acts of nature and availability of merchandise.

It is our policy to continuously improve designs, materials and manufacturing methods in order to provide you with the finest products. Therefore, variations in specifications, materials, prices, styles and finishes may be made without notice.

NO RETURNS ON CUSTOM OR VALANCE UMBRELLAS.

THE SELLER DISCLAIMS ANY IMPLIED WARRANTY OF MERCHANTABILITY.

Those filing warranty claims will be responsible for all shipping, handling, and freight charges on all claims to Shademaker in Baldwin Park, CA. All warranty claims must be submitted with the original proof of purchase, date of purchase, name of dealer, and the description of the damage. The Shademaker warranty is not transferable. Shademaker reserves the right to repair, replace, and/or redesign any product that is returned under a warranty claim.

LOGO SUBMISSION FORM

CONTACT INFORMATION

Date: _____ Contact: _____

Company Name: _____

Project/Logo Name: _____

LOGO INFORMATION:

Umbrella Model: _____ Size: _____ Order Qty.: _____

Fabric: _____ Color: _____

Number of Logos per Umbrella: _____ Totaling: _____ Printed Logos.

Logo Color(s): _____

Size of Requested Finished Logo(s): _____

Placement: Mark panels and/or valances below. *(For side post styles, note position of mast)*

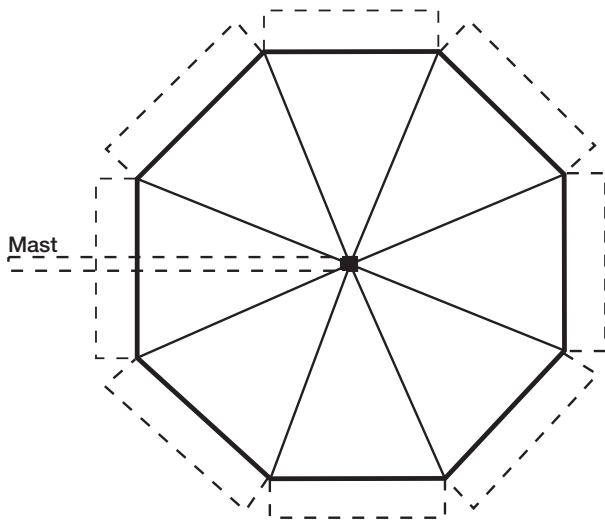

Octagon

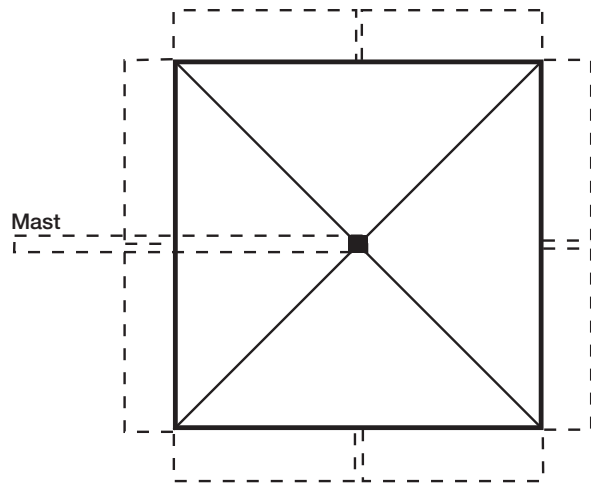

Square*

** Note: Split valance on all styles
(except LIBRA-20S).*

**In order to obtain a quote, you
MUST submit logo in vector format,
along with this completed form.**

FOR OFFICE USE ONLY

Quote: \$ _____ Date: _____ Initials: _____

Additional Notes: _____



SHOWN | **LIBRA-25S**
In 5816 Aqua
